

STATE	PROJECT NO.	SECTION NO.	SHEET NO.
ND	Project Number	100	3

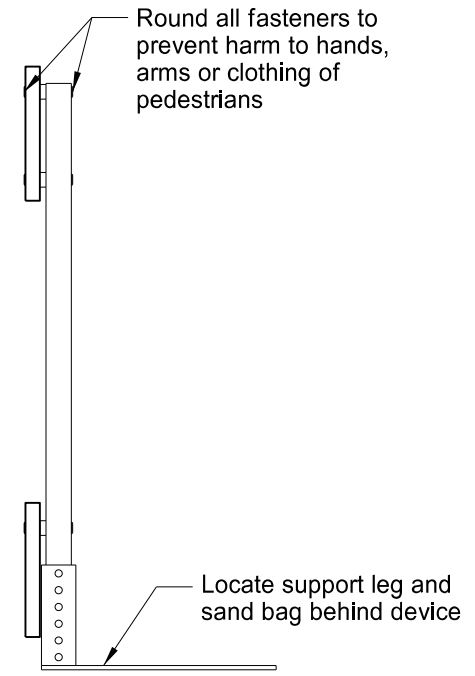
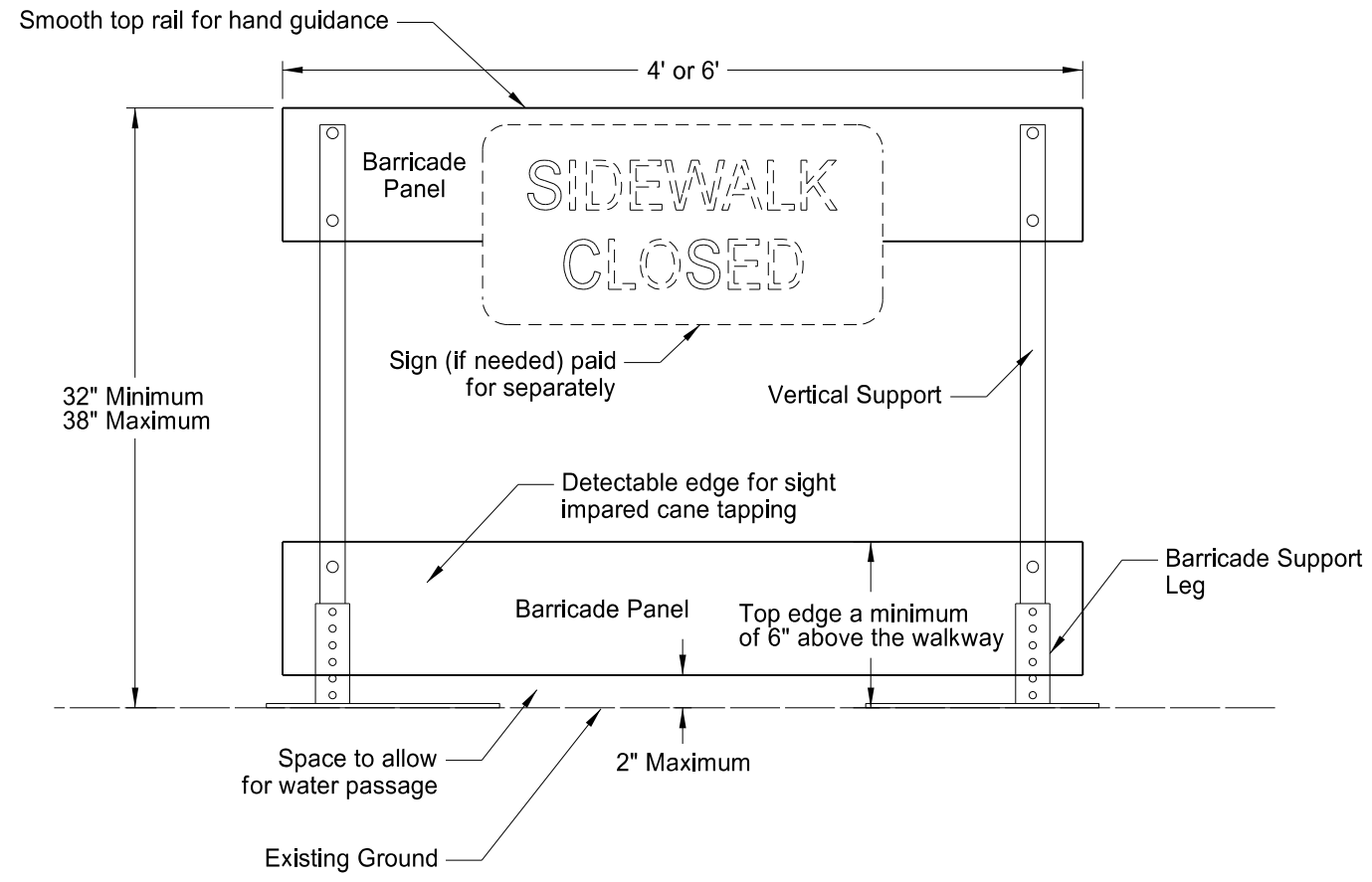

NOTES:

Sidewalk Barricades

1. Provide self standing sidewalk barricade with no supports extending into the pedestrians path.
2. Use orange or orange and white diagonal striped barricade panels contrasting with the walkway surface.
3. Provide ADA compliant and NCHRP 350 or Mash Test Level 3 (TL3) approved sidewalk barricades.
4. Include all costs to furnish, maintain and remove sidewalk barricades in the price bid for "Sidewalk Barricade".

Front View

End View

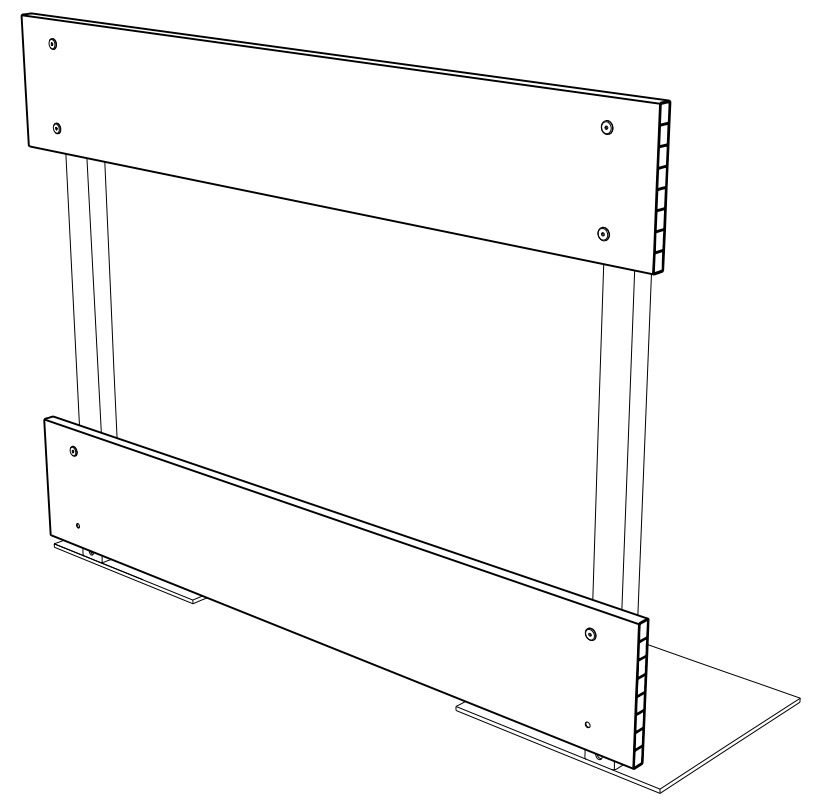

Perspective View

This document is preliminary and not for construction or implementation purposes.

Sidewalk Barricade
Project Description
Project Location