

Notes:

1. Place a spacer material, that is easily removable after the pour, on the transverse joint face to maintain the width of the existing transverse joint during repair. A bituthene waterproofing material a minimum 260 mil (approximately 1/4") thick or equal to the width of the existing joint, whichever is greater, may be used for this purpose. Cut it to fit over the entire face of the existing joint to provide for expansion and prevent water from entering the existing joint through the sides or bottom. Press it into place to conform to the face of the existing joint.
2. Diamond saw cut not mandatory when using milling machine for spall repair removals.

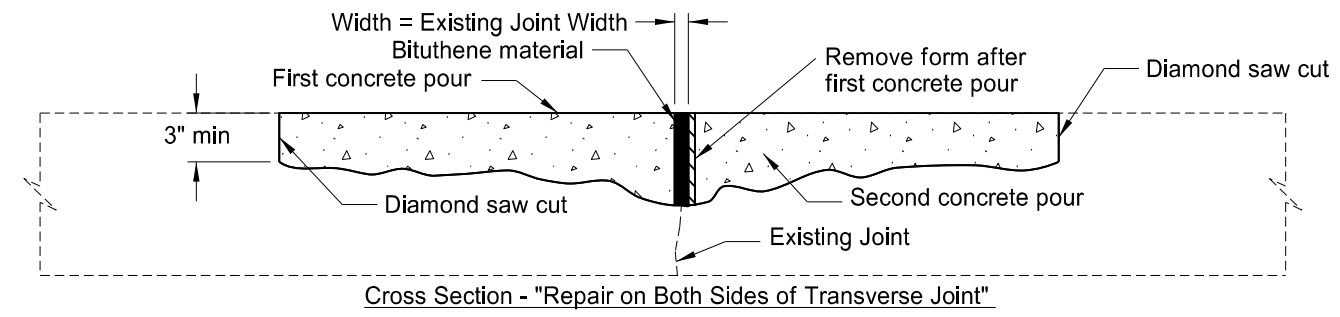

This document is preliminary and not for construction or implementation purposes.

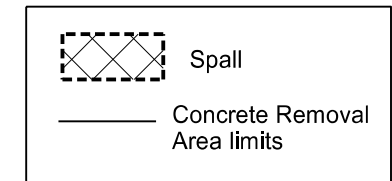

Jointed Non-Reinforced PCC Pavement Spall Repair Detail
Project Description
Project Location