

TRANSVERSE JOINTS

** Joint Spacing to match existing (Varies from 14' to 18')

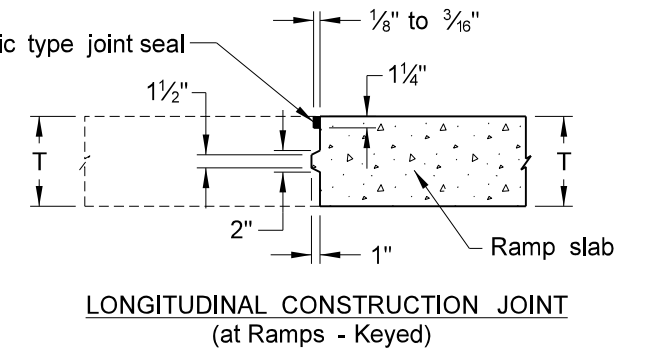

This detail provides for narrow sawed joints with hot poured elastic type joint seals for the cpr repaired joints. If you are resealing the joints on the entire project with silicone, replace the Transverse Joint Sawing and Sealing details below with the details outside the border of this plan sheet and revise the joint size on all details as appropriate. Delete this text before using this detail in the plans.

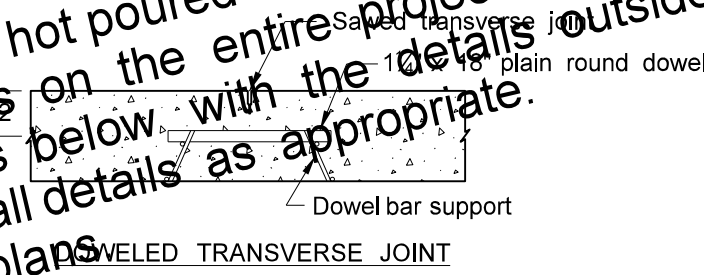
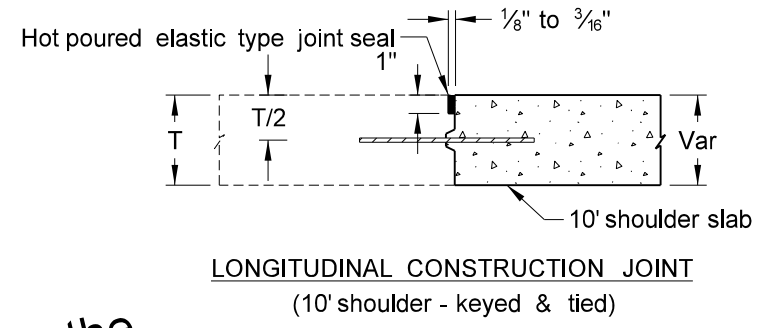
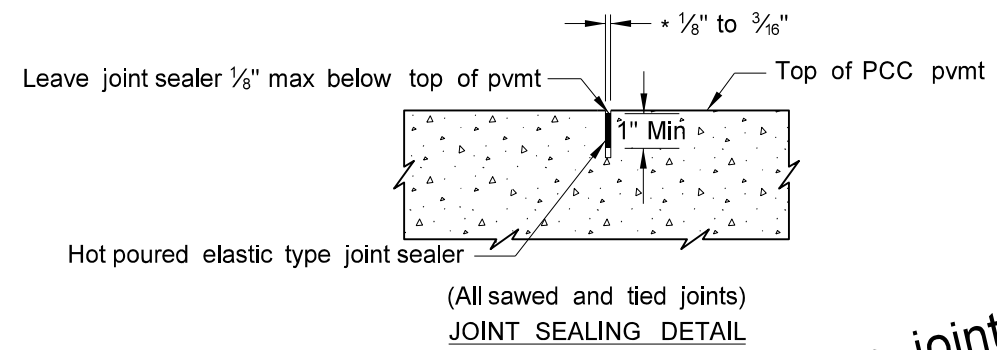
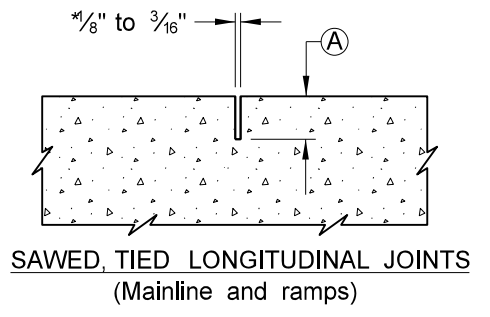
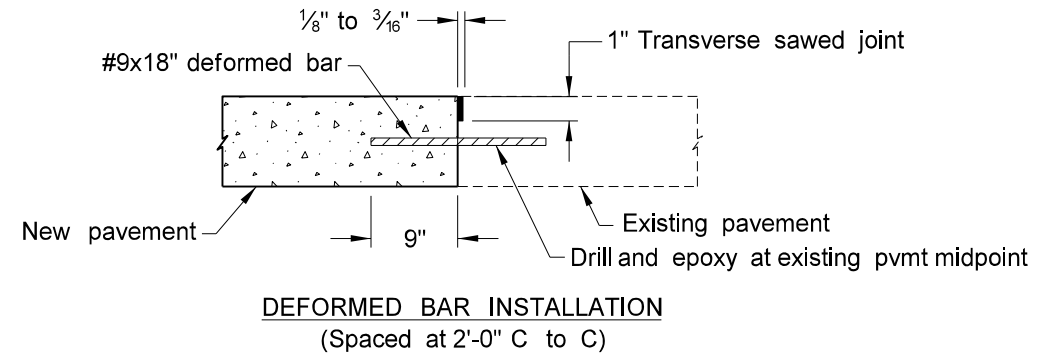
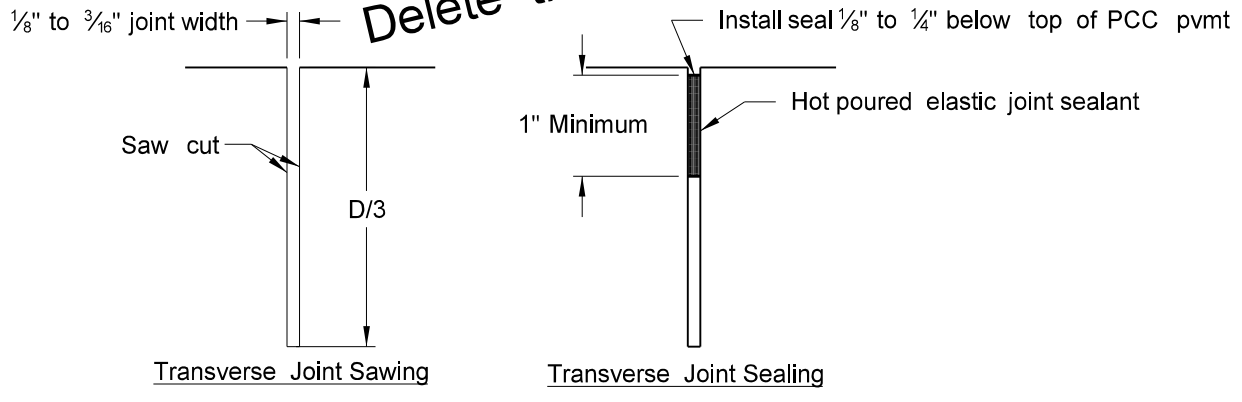

T = Thickness of PCC Pvmt
 (A) = One-Third thickness of PCC Pavement
 *Width requirement for top 1" only, bottom portion of sawcut may be narrower.

This document is preliminary and not for construction or implementation purposes.

Joint Details for Repairs 1 Panel or More in Length
 Concrete Pavement Repair
 Project Location